

# 7 Series IP68 Submersible Fluorescent

Cat. II  
Zone I

ATEX  
CERTIFIED

sira  
Sira Certification Service

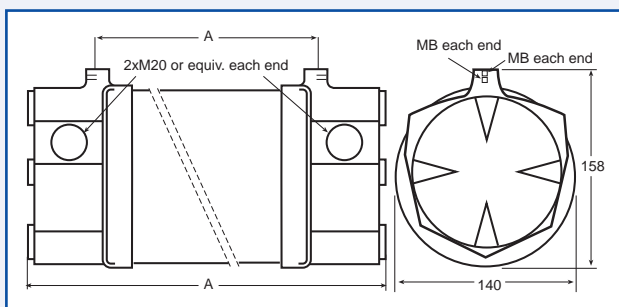

Project/sample luminaires:  
2 x 28w T5 1200mm lamps standard.  
2 x 28w T5 1200mm lamps auto self-test emergency

For size 4 (1200mm nominal lamp)  
A = 1242mm, B = 1362mm.

## Features

- Simple but robust shape and construction using polycarbonate housing – high strength & impact resistant tube plus marine grade aluminum end casting & cover.
- Multiple length options.
- Multiple wattage options.
- Multiple lamp type options – T5, T8, PL, etc.
- Auto self-test for emergency luminaires, extends battery life using weekly & 3 monthly test regime.
- No entry to luminaire required to test/check - multi colour status LED's viewed from below.
- Versatile luminaire mounting system.
- Enclosures pressure tested routinely to 12 BAR.
- Submersion tested to 20m plus drag testing.
- Easily accessible electrical components.
- Balanced fitting therefore easier mounting.
- No separate battery packs therefore helping to extend lifetime.
- Client choice of ballast possible.
- Internal polished aluminium reflector completely protected by mounting internally.

## Certification & Approvals

Certification Standard: EN60529: 1991  
Incorporating Amendments  
Nos. 1 & 2  
Certificate Number: 04TEST1315  
Degree of Protection: IP 68, 32m to IEC 529: 1989  
(using correct installation  
methods)

## Sales and Technical Support

Please contact PFP for any technical advice you may require including photometric details.  
A technical design service is available for all our customers.

**PFP**  
Petrel Fitter & Poulton

Tel: +44 (0) 121 783 7161 • Fax: +44 (0) 121 783 5717  
www.pfp-elec.co.uk • sales@pfp-elec.co.uk